

STANFLO

Air Operated Double Diaphragm Pumps

ST8 Metal Pump

FLOW RATE TO 163 GPM (617.02 LPM)
 MAXIMUM OPERATING PRESSURE = 125 PSI (8.6 BAR)

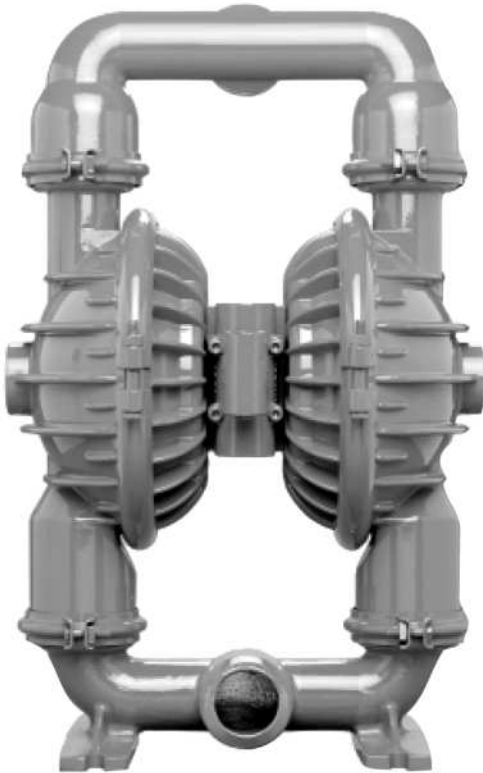

SPECIFICATIONS

WETTED HOUSINGS (Water Chambers and Manifolds)

MATERIAL	SHIP WT.
Aluminum	72 lbs. (33.1 kg.)
Cast Iron	114 lbs. (52.4 kg.)

NON-WETTED HOUSINGS

DESCRIPTION	MATERIAL
Air Chamber	Aluminum
Center Block	Aluminum
Air Valve	Brass

MAXIMUM SUCTION LIFT CAPABILITY

DRY LIFT	WET LIFT
21' (6.4 m)	31' (9.45 m)

MAXIMUM DIAMETER SOLIDS

1 / 4" (6.35 mm) Diameter

ELASTOMER OPTIONS

MATERIAL	TEMPERATURE LIMITS
Neoprene	0 (-17.8) to +200 (93.3) F° (C°)
Buna-N®	+10 (-12.2) to +180 (82.2) F° (C°)

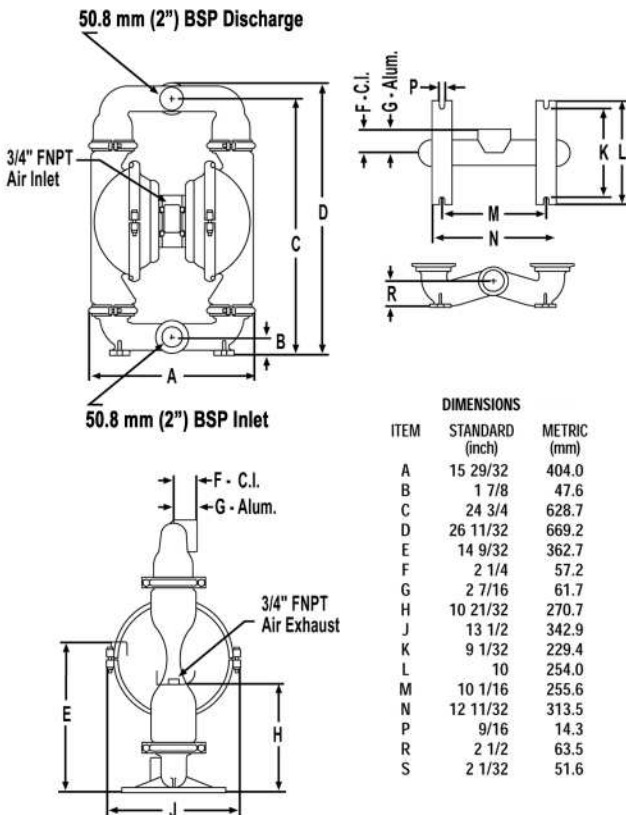

PERFORMANCE CURVE

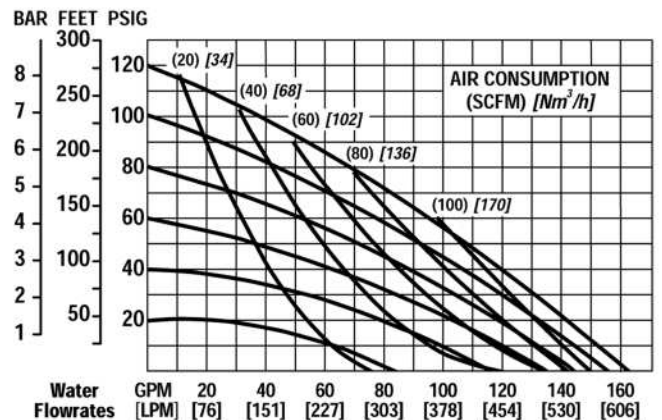

Authorized Distributor